



MATERIALS & FINISHES COLLECTION



acoustic & audio solutions

Version: 1.1

Material selection has always been central to the design of our loudspeakers and sound absorbing panels. We use architectural finishes and surfaces, uncommon in the audio industry, made in Italy and created to blend naturally into a wide range of environments.

This catalogue has been developed to present the textures, techniques, and aesthetics of the materials we use. These surfaces are not simply finishes, but an integral part of the acoustic concept, the product design, and the overall user experience. It is a practical reference for professionals and clients, offering a clear overview of textures, colours, compositions, and application possibilities, to support informed choices for each project.

MATERICA 4-5

TAYLOR 6-7

ECO 8-9

MARBLE 10-11

GRES 12-13

PAINTINGS 14-15

SPECIAL PAINTINGS 16-17

GALVANIC 18-19

GOCCIA 20-21

POLYETHYLENE 22-23

CEMENT 24-25

CORIAN 26-27

HPL 28-29

SUGGESTION GRAPHIC PRINT 30-31

Materica™

Surface®
collection
acoustic panel

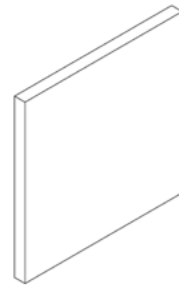

Microbaffle®
collection
acoustic panel

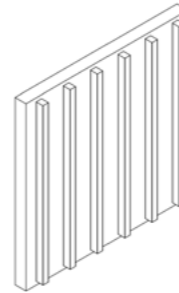

Parquet®
collection
acoustic panel

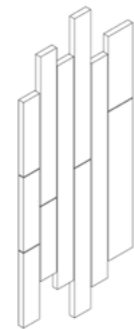

Materica is a finish developed and tested in our reverberation room, created to give surfaces a richer and more substantial appearance, reminiscent of concrete or plaster, while maintaining the sound absorbing properties of the underlying material. The Materica finish is the result of selected components and a special handcrafted process that makes every surface unique.

Materica WALL™
Gray Shades
on White fiber



MC31



MC32

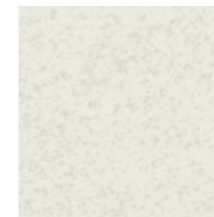

MC33

Materica WALL™
Colour Shades
on White fiber

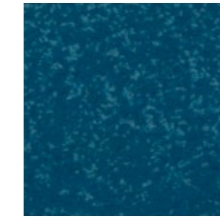

MC51

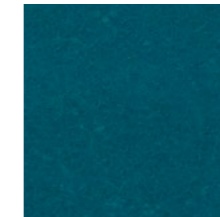

MC52

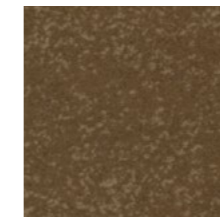

MC53

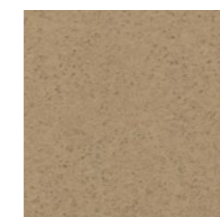

MC54



MC55



MC56

Materica CEMENT™
Gray Shades
on Black fiber



MC11

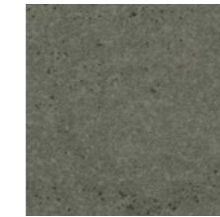

MC12



MC13

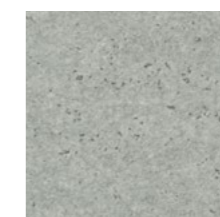

MC14

Custom colours



MC
on white fiber or
black fiber



TAYLOR fabric / tessuto

TAYLOR fabric / tessuto

CinemAtelier®
collection
acoustic panel

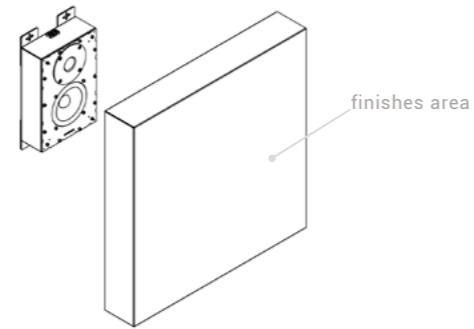

Coro®
collection
on-wall/bookshelf
speaker

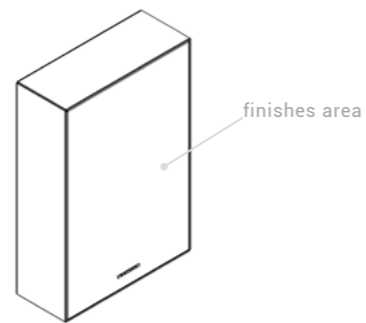

Aesthetic cover
on-wall/bookshelf
speaker

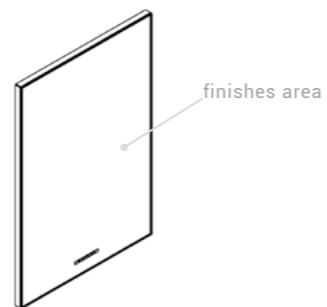

COMPOSITION: 100% Polyester
ABRASION RESISTANCE: UNI ISO 12947/2 100.000
+ 10% martindale
FLAMMABILITY: EN1021/1-2 CRIB 5 BS 7176
Medium Hazard California TB117 UNI 9175 Class 1JM
OEKO-TEX STANDARD 100



TT01

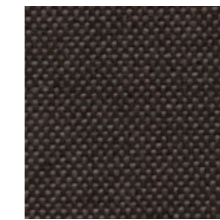

TT26

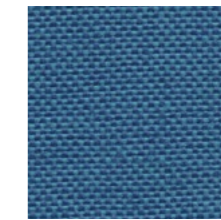

TT12

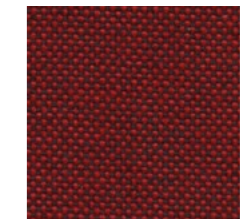

TT34

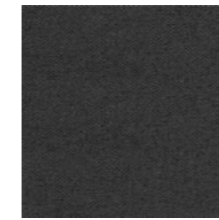

TT02

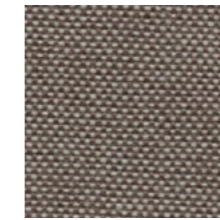

TT25

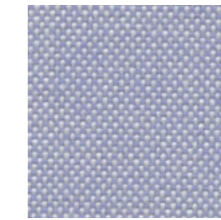

TT15

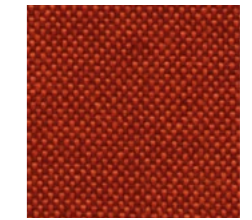

TT32

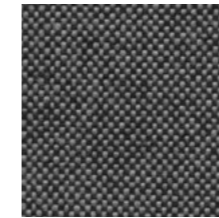

TT03

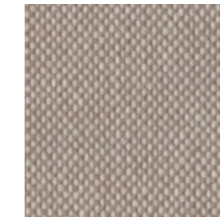

TT24

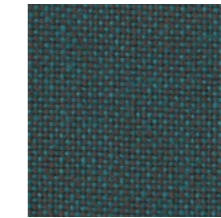

TT13

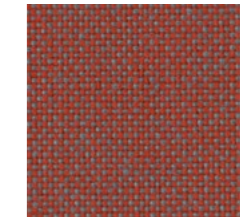

TT31

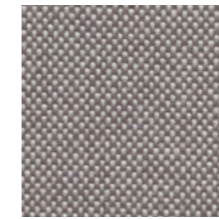

TT04

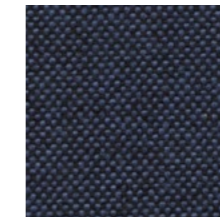

TT17

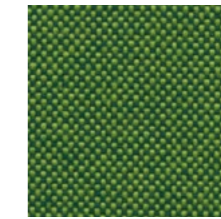

TT09

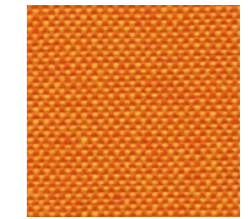

TT30



TT05

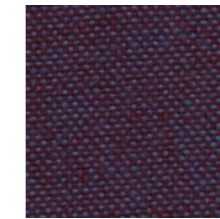

TT19

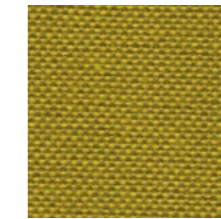

TT08

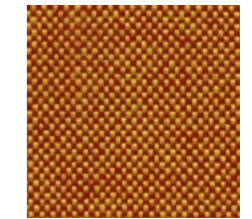

TT28



TT23



TT20



TT06



TT22

ECO fabric / tessuto

ECO fabric / tessuto

Surface®
collection
acoustic panel

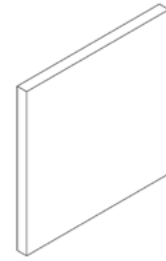

Microbaffle®
collection
acoustic panel

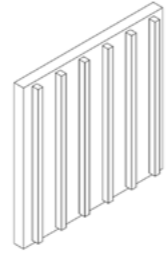

Parquet®
collection
acoustic panel

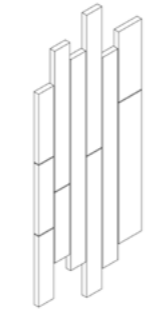

CinemAtelier®
collection
acoustic panel

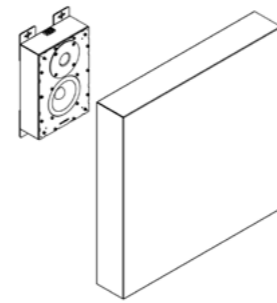

Aesthetic cover
on-wall/bookshelf
speaker

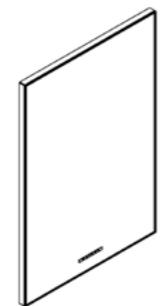

TE01

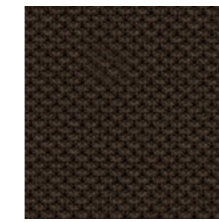

TE27

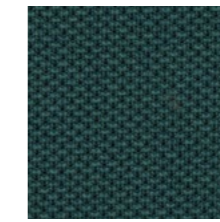

TE15



TE39

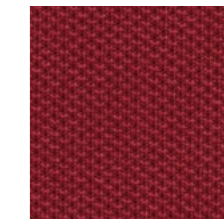

TE35

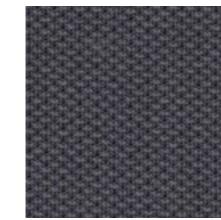

TE02



TE24

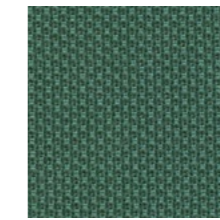

TE11



TE32

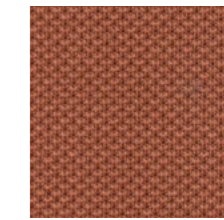

TE34

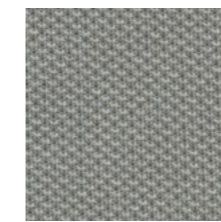

TE04



TE23

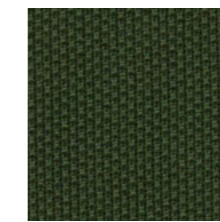

TE08

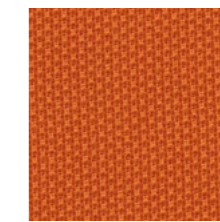

TE31

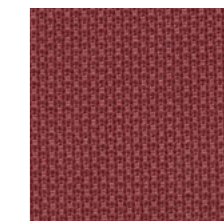

TE36



TE06



TE21



TE10



TE29



TE37

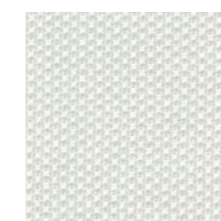

TE07

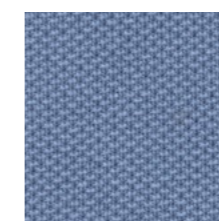

TE19

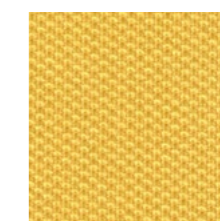

TE28

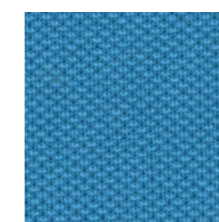

TE17

COMPOSITION: 100% Recycled Polyester
 ABRASION RESISTANCE: UNI ISO 12947/2 100.000
 FLAMMABILITY: EN1021/1-2 CRIB 5 BS 7176
 Medium Hazard California TB117 UNI 9175 Class 1JM
 OEKO-TEX STANDARD 100

GRES MARBLE EFFECT finishes

GRES MARBLE EFFECT finishes

Loto®
 outdoor speaker 360
 SA225
 WA125

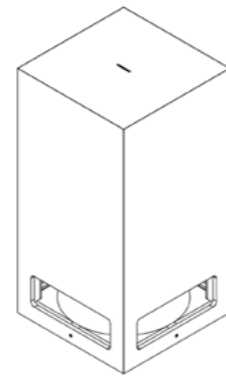

Marble 1
GF



Loto®
 outdoor speaker 360
 SA117

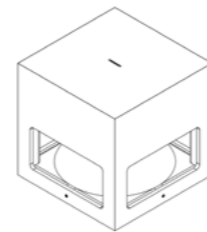

Marble 2
GG



Loto®
 outdoor speaker 360
 WA138

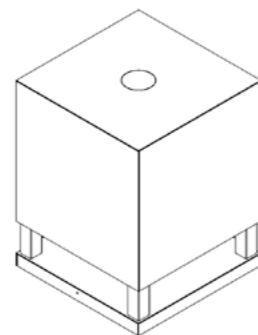

Marble 3
GH

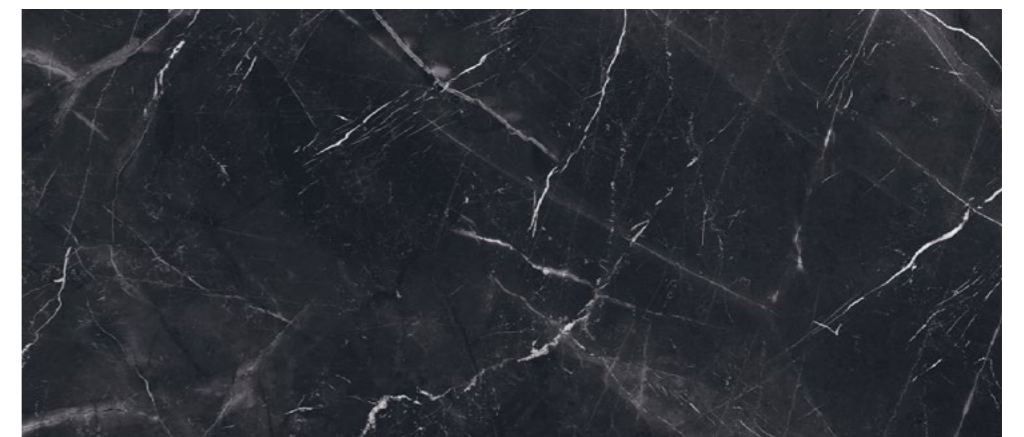

Marble-effect gres porcelain combines the elegance of natural stone with refined surfaces, realistic veining, and harmonious colour variations. This finish gives the loudspeakers a sophisticated architectural appearance, ideal for residential environments and representative spaces. From a technical point of view, gres porcelain offers high stability, resistance to external agents, and a compact surface, ensuring reliable performance over time, even in outdoor applications.

GRES finishes

Loto®
outdoor speaker 360°
SA225
WA125

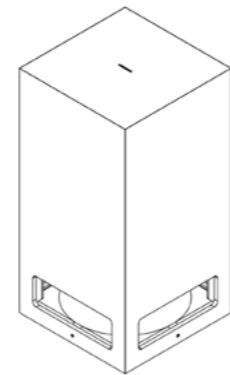

Loto®
outdoor speaker 360°
SA117

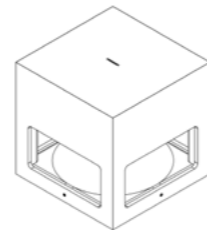

Loto®
outdoor speaker 360°
WA138

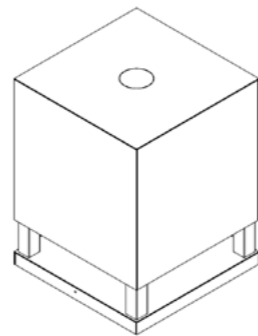

Material-effect gres porcelain enhances the tactile and visual qualities of the surface, drawing inspiration from cement, stone, and industrial textures. These finishes are defined by strong visual depth and a contemporary character, making them especially suitable for modern architectural projects. From a technical point of view, gres porcelain offers robustness, durability, and dimensional stability, making it suitable for both indoor and outdoor applications.

GRÈS finishes

Ivory
GA



Rope
GB

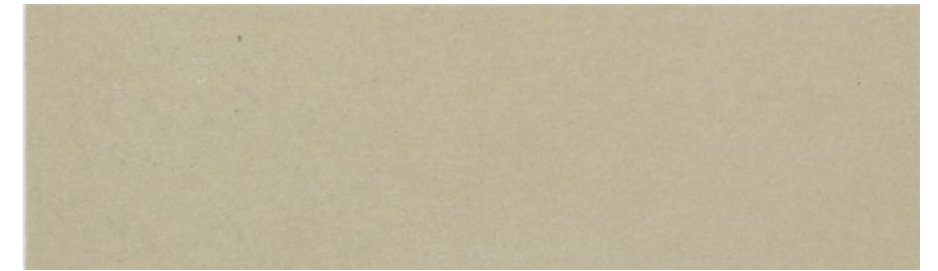

Mud
GC



Grey
GD

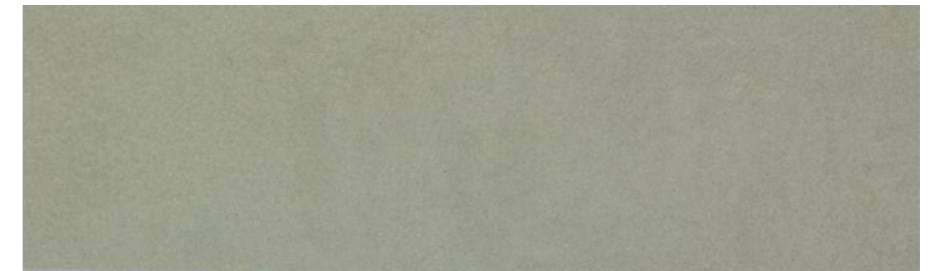

Graphite
GE

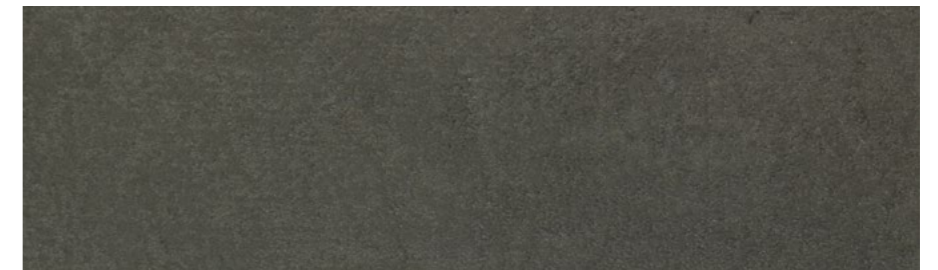

PAINTINGS

CLASSIC PAINTINGS

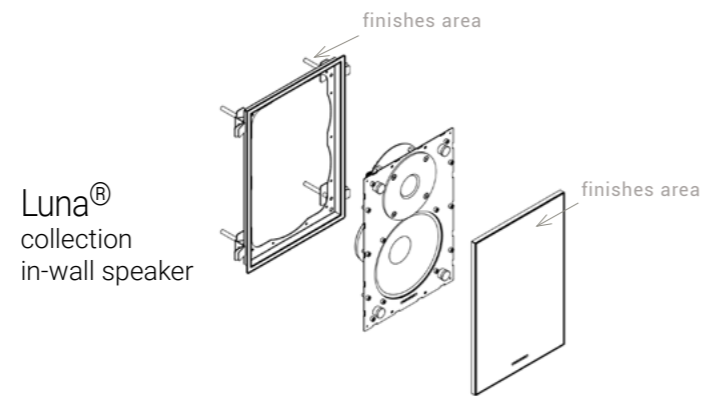

Paintable Matte White
RAL 9016

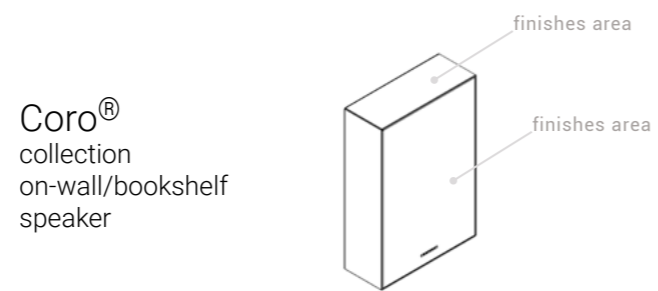
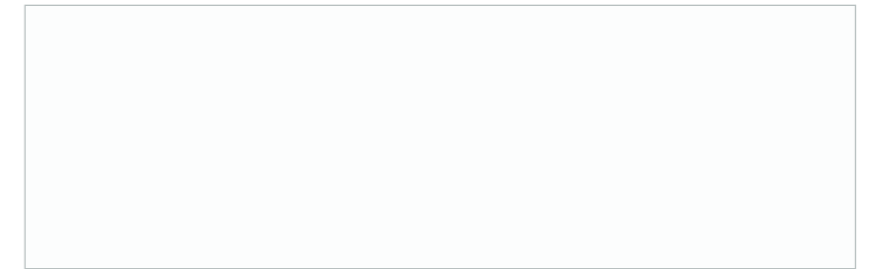

Matte Black
RAL 9005

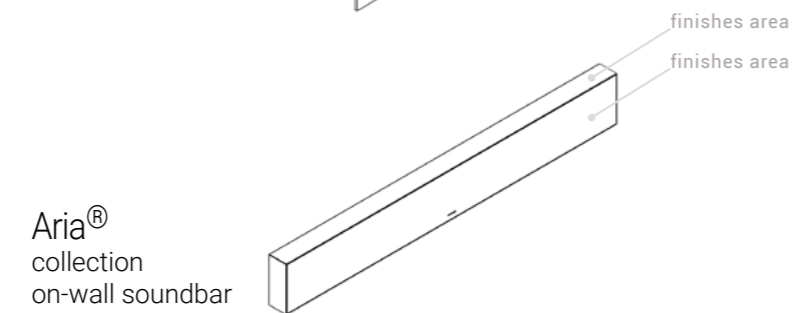
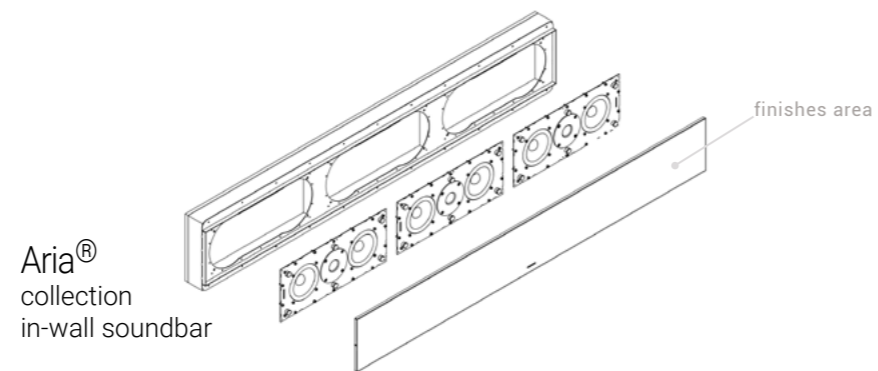

Customized paint finishes based on the RAL and NCS colour systems allow precise and repeatable colour definition. These standards make it possible to coordinate loudspeakers seamlessly with architectural elements, furnishings, and surrounding surfaces. The painting process is developed to ensure uniform coverage, colour accuracy, and long term durability, with different surface finish options available.

SPECIAL PAINTINGS

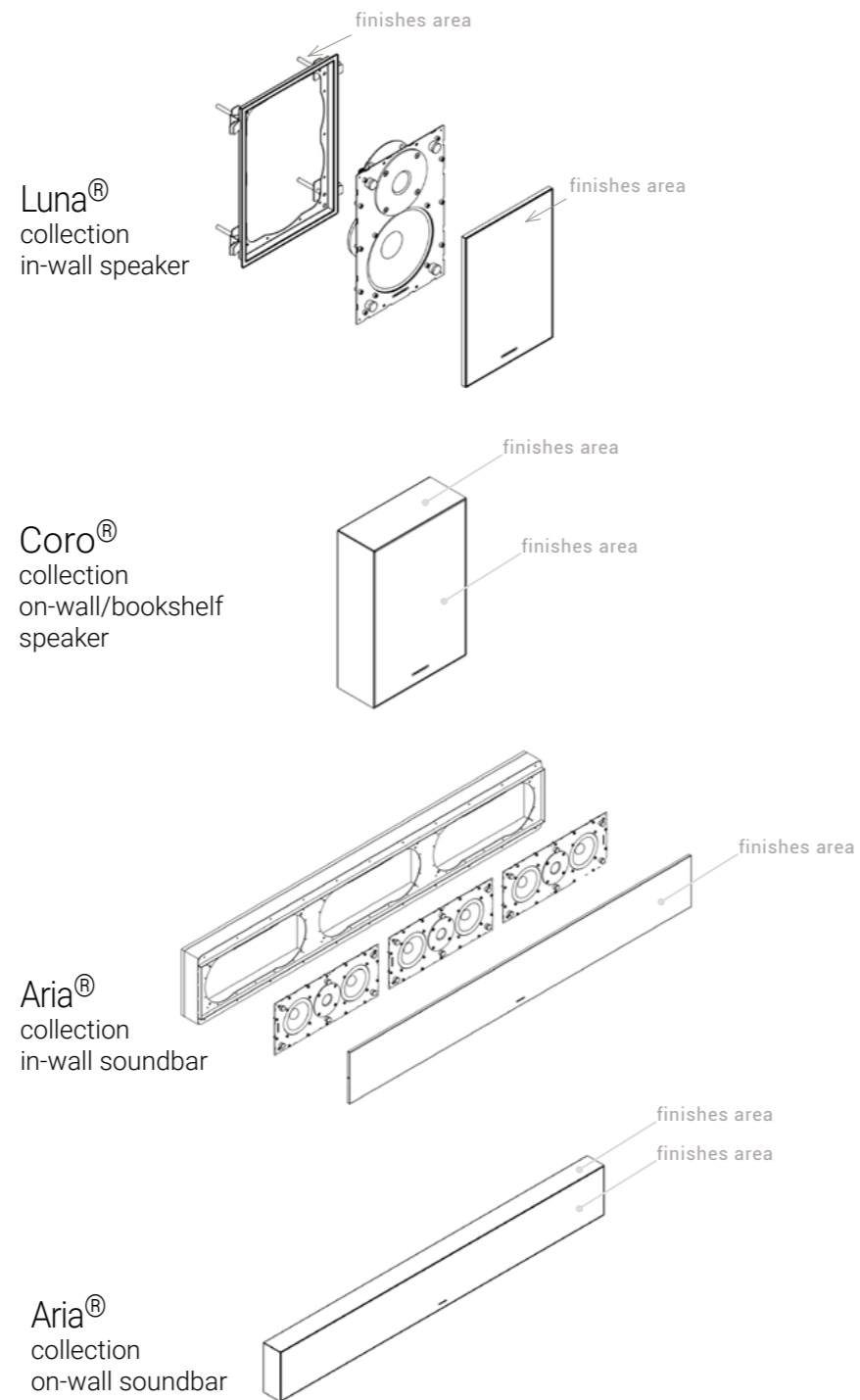

Special coatings make it possible to create customised surfaces with distinctive aesthetic effects. Finishes can be matte, satin, or textured, and are designed to harmonise with the surrounding architecture. Controlled application cycles ensure uniformity, colour stability, and surface resistance, combining broad design freedom with technical reliability.

SPECIAL PAINTINGS

Brushed Brass
L24



Matte Gold
L23



Matte Rose Gold
L22

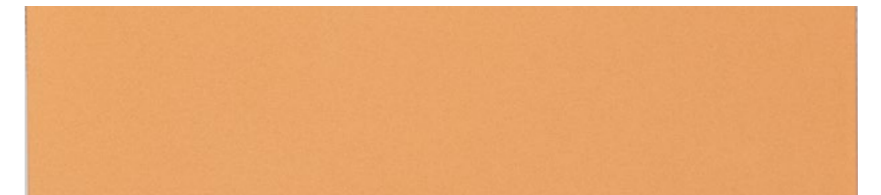

Corten
L31

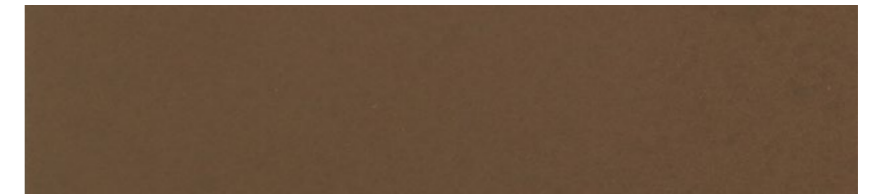

Matte Bronze
L20

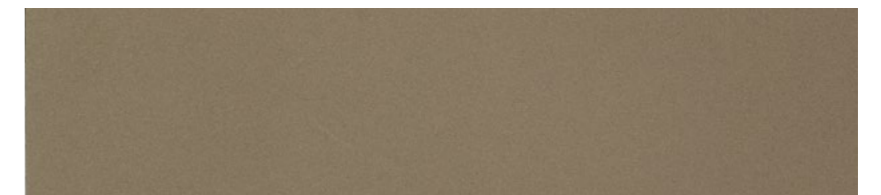

Matte Silver
L19

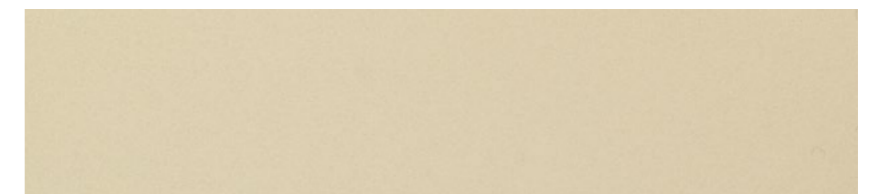

Matte Titanium
L18

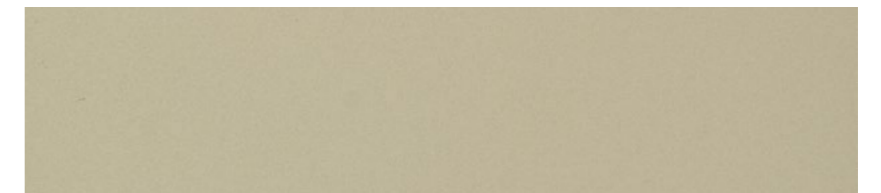

RAL & NCS color



GALVANIC finishes

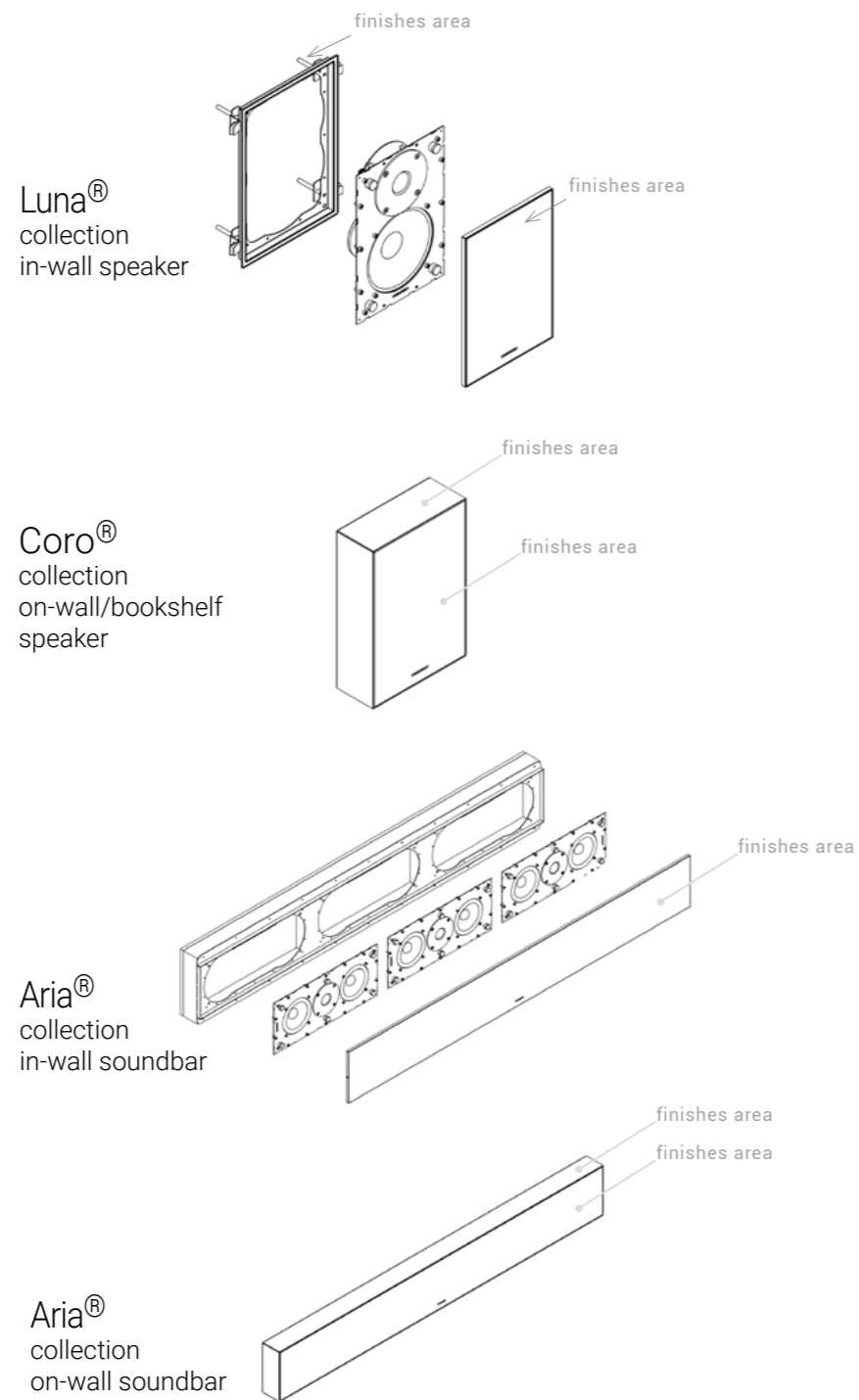

Galvanic finishes are created through an electrochemical process that deposits a uniform metallic layer onto the surface. The result is a refined and luminous finish, defined by controlled reflections and elegant tones that enhance the formal details of the product. In addition to their aesthetic value, galvanic treatments improve surface protection and long term durability, helping to preserve a clean and consistent appearance over time.

GALVANIC finishes

Glossy Chrome
V27



Brushed Chrome
V28



Brushed 24 Gold
V23



Brushed Rose Gold
V22



Brushed aged Bronze
V24



GOCCIA™
ceramic finishes

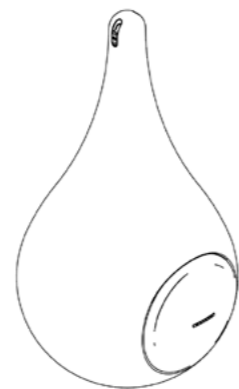
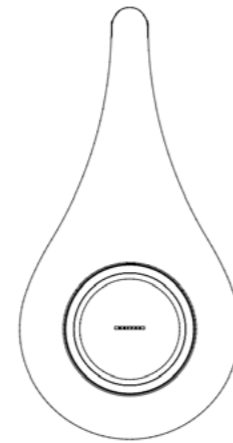

Every Goccia ceramic hanging speaker is a one-of-a-kind piece, meticulously handcrafted by the master artisans of the Gatti workshop in Faenza. Stunning finish options include pearlescent colors, precious metals such as gold, platinum, and copper, together with the two exclusive decorative finishes, Riflesso and Decoro.

Pearl colours



White
SVK15GB



Violet
SVK15GM



Red
SVK15GD



Green
SVK15GV

Gloss



White
SVK15PB



Grey
SVK15PY



Black
SVK15PN



Black
SVK15TN

Metallic colours



Platinum
SVK15MP



Copper
SVK15MR



Gold
VK15MG

Special



Riflesso
SVK15RF



Decoro
SVK15DB

POLYETHYLENE finishes

Celeste®
suspended speakers
KN116

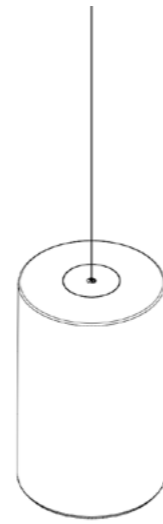

Loto®
outdoor speaker 360°
KN116



Loto®
outdoor speakers
SN120
SN220
WN120



Polyethylene is a technical polymer material characterised by a fine and controlled surface texture. This subtle finish enhances visual depth and reduces reflections, giving architectural loudspeakers a refined and contemporary appearance. From a technical point of view, polyethylene offers excellent resistance to humidity, UV exposure, and weathering. Its impact resistance and material stability ensure long term durability and reliable performance in both indoor and outdoor applications.

POLYETHYLENE finishes

Green
V

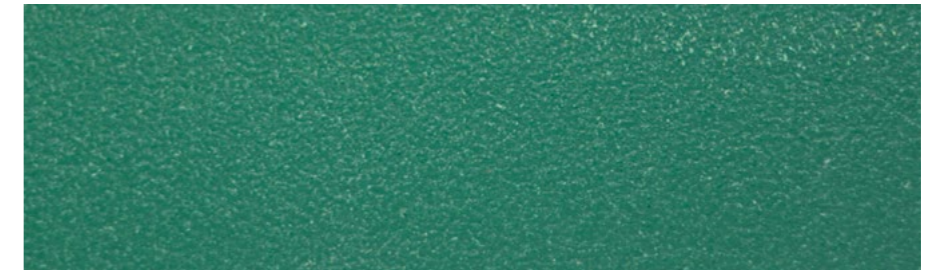

White
F

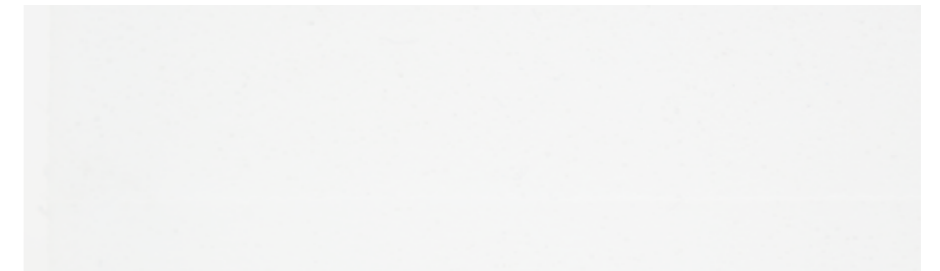

Gray
Y

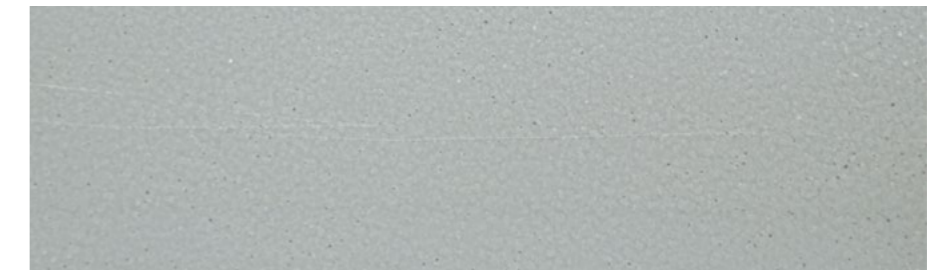

Anthracite
A

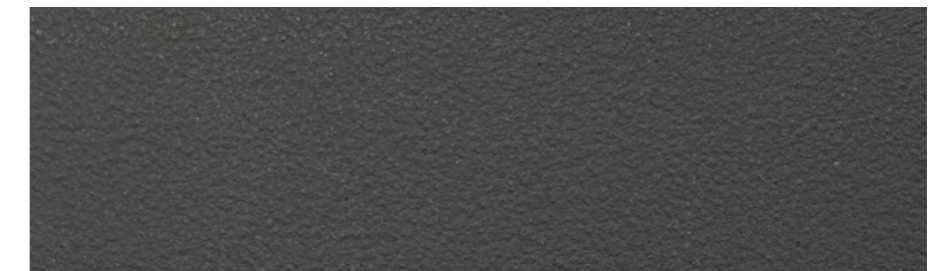

Corten Effect
Z

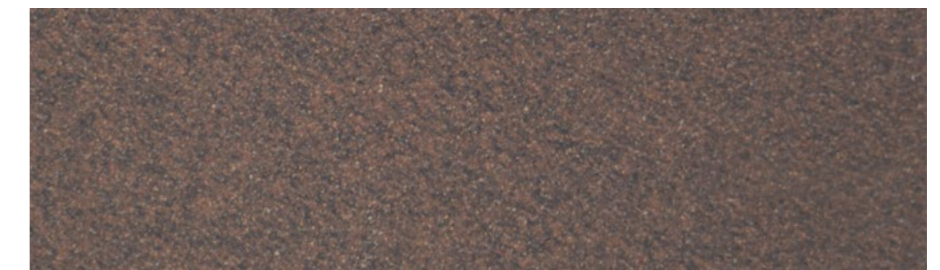

CONCRETE finish

Loto®
outdoor speakers

SN120
SN220
WN120



CONCRETE finish

Gray
EA



Concrete expresses an authentic material character, defined by subtle tonal variations and micro irregularities that make each piece unique. This finish gives the loudspeakers a strong architectural identity and a contemporary appearance. From a technical point of view, concrete offers solidity, structural stability, and reliability even in demanding environmental conditions.

CORIAN finishes

Solid Surface

Loto®
outdoor speaker 360°

SA225

WA125

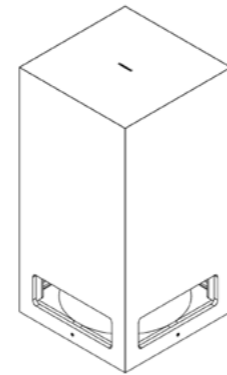

Loto®
outdoor speaker 360°

SA117

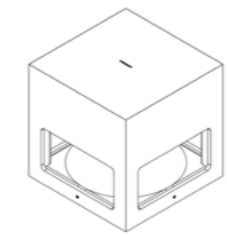

Loto®
outdoor speaker 360°

WA138

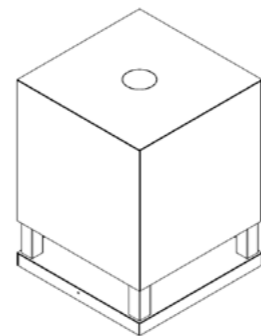

CORIAN finishes
Solid Surface

White

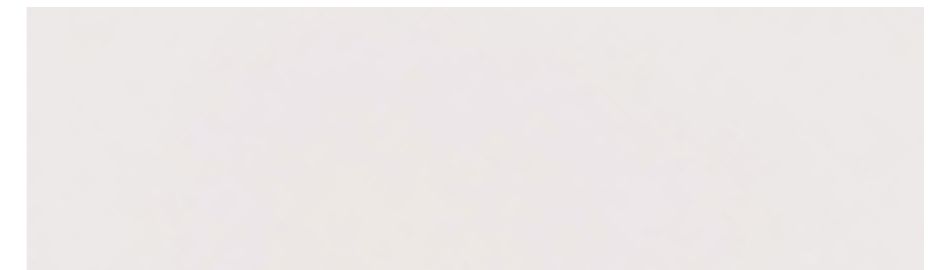

Corian combines a smooth, homogeneous, and seamless appearance with excellent technical performance. Its clean and refined aesthetic allows for elegant and minimal designs, making it ideal for architectural loudspeakers where form and material integration are essential. From a technical point of view, Corian offers excellent dimensional stability, surface uniformity, and resistance to humidity and external agents. It can be machined and shaped with precision, allowing refined geometries and high quality finishes specifically developed for outdoor applications.

HPL finishes

Loto®
outdoor speaker 360°

SA225

WA125

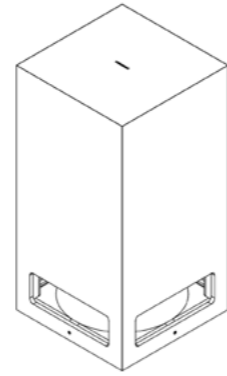

Loto®
outdoor speaker 360°

SA117

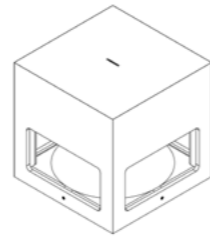

Loto®
outdoor speaker 360°

WA138

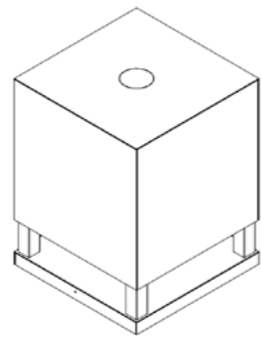

Gray
H32

Anthracite
H33

Corten
H31

HPL finishes

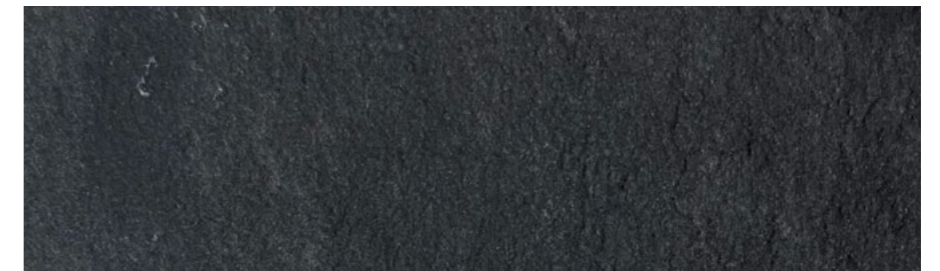

HPL is a technical material produced through the high temperature pressing of resin impregnated layers. The resulting surfaces are compact, uniform, and available in a wide range of colours and textures. From a technical point of view, HPL offers excellent resistance to humidity, UV radiation, and weathering, making it a versatile and reliable solution for outdoor architectural applications.



SUGGESTION
Graphic print
CUSTOM
Graphic print

Surface®
collection
acoustic panel

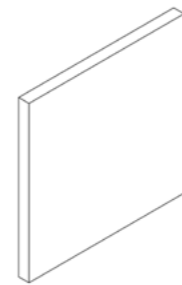

CinemAtelier®
collection
acoustic panel

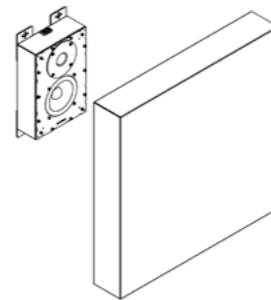

Aesthetic cover
on-wall/bookshelf
speaker

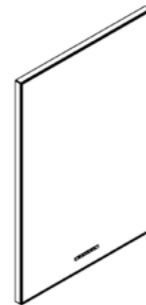

Discover a new aesthetic and functional dimension through our innovative graphic designs. Carefully curated for a wide variety of environments, these prints bring personality and style to sound absorbing panels.



MADE IN ITALY

3+1+1 YEAR WARRANTY

Via Vittori, 21/1-2
48018 Faenza (Ra) Italy
Tel. +39 (0546) 682097
garvan@garvanacoustic.com

Follow us on:



www.garvanacoustic.com